

RXC/SE

HEAT RECOVERY UNITS WITH PLATE HEAT EXCHANGER

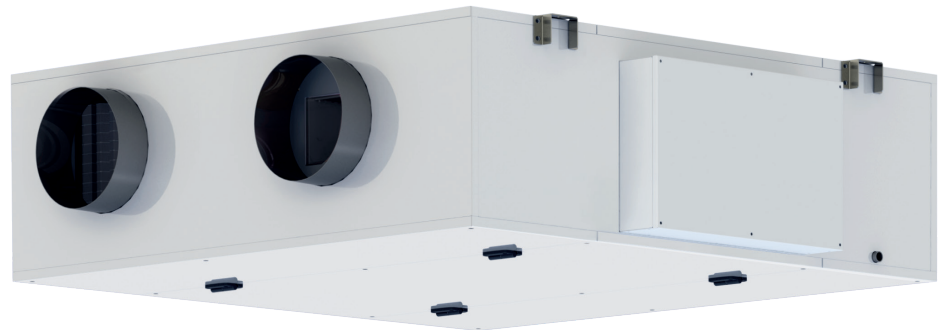

INTRODUCTION

The sick building syndrome is a disease recognized by the World Health Organization that presents a series of symptoms due to the presence of toxic elements in the workplace. The main sources of pollution originate both from factors inside and outside the building.

Replacing the air, not wasting energy, is the solution. Thanks to the installation of Controlled Mechanical Ventilation systems it is possible to guarantee the correct air exchange and filtration.

The heat recovery units provide the air exchange together with the recovery of a part of the thermal energy of the

extracted air which is given to the fresh air at practically no cost; therefore a pre-heating in winter or a pre-cooling in summer of the introduced air is obtained, moreover they bring other advantages such as air filtration and a smaller sizing of the heating and cooling systems, allowing savings both during the purchase and the conduction of the same. The recovery units of the RXC/SE series are available in 7 sizes, with nominal air flow rates from 400 to 4000 m³/h. The units have been designed for false ceiling installation (H) or ground installation (V) and are available in the **ECO**, **PLUS**, **TOP** version.



MAIN CHARACTERISTICS

1 | STRUCTURE

Self-supporting structure in sandwich panels with internal insulation made of high density polyurethane foam (40 kg/m³). The panels are 25 mm thick and are made of 6/10" thick steel sheets, the external side is pre-painted RAL 9010, the internal side is hot-dip galvanized Z140. The structure is made according to the EN1886 standard, class D1 mechanical resistance. A particularly adaptable and resilient neoprene gasket guarantee the air tightness. Screws that ensure an adequate and constant pressure on the gaskets fix the opening panels. In all areas subject to condensation is present a condensate drip tray, inclined internally and in compliance with EN 1.4301.

All internal components are accessible from below by means of removable panels in order to guarantee the correct ordinary and extraordinary maintenance.

3 | FILTERS

The units can host different types of filters, both in the room air extract and in the fresh air intake.

They are mounted on guides equipped with gaskets to guarantee effective sealing. Their position, upstream of the internal components, also guarantees their protection.

4 | FANS

Independently controllable, they consist of aerodynamically balanced, statically and dynamically balanced forward blade centrifugal impellers with aerodynamic profile, made of galvanized steel. The impellers are directly coupled to EC brushless motors, with internal rotor, operating via a 0-10V signal.

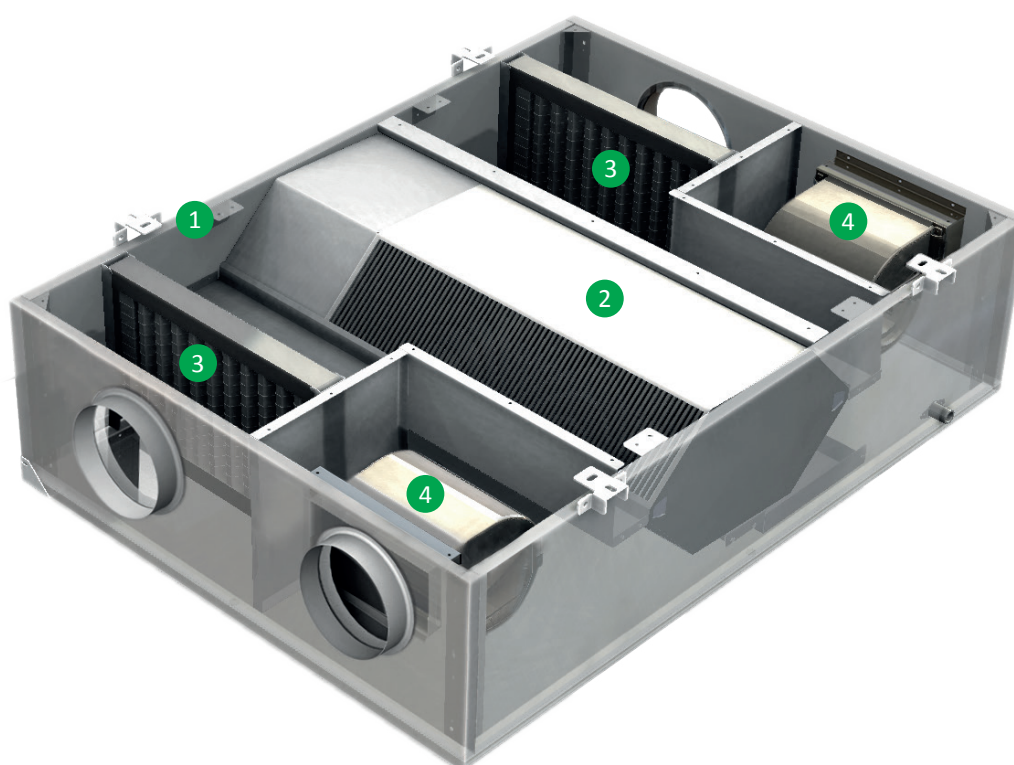

2 | HEAT RECOVERY

The units are equipped with an aluminium counter-flow heat exchanger used to transfer heat from the exhaust air to the fresh air. The heat exchange takes place in counter-flow with efficiency higher than 80% in dry air, according to the ECO Design and Eurovent approval. The spacing between the fins is optimised in order to reduce air side pressure drop and fan power consumption. The heat recovery is also equipped with an additional by-pass damper for the management of the free-cooling and free-heating mode as per ERP regulation. By-pass damper 100% of the airflow rate. The heat exchanger participates to the

Eurovent Certification program and it is sized according to the **ECO Design** specification.



DEFROST SYSTEM (optional)

The automatic defrosting system can be carried out either electrically (consists of a self-regulating electric coil installed on the return air intake), or with unbalanced airflows (consists of a specific device and software that avoid an excessive drop of the exhaust air temperature).

ADDITIONAL COILS (optional | external module)

External module that can accommodate heating and/or cooling coils with a high number of rows.

The module can also accommodate combined coils (water cooling, water and/or electric heating).

TECHNICAL DATA

MODEL		005	006	010	015	020	030	040	
Type of ventilation unit		UVNR-B (Non Residential Ventilation Units - Bidirectional)							
Type of drive installed		Analog signal on EC fan (0-10Vdc)							
Type of fans	type/nr.	EC/2	EC/2	EC/4	EC/2	EC/2	EC/2	EC/2	
Type of heat recovery system (HRS)	type/nr.	static counter-flow / 1							
Winter Thermal Efficiency (η_{t_nrvu}) ⁽¹⁾	%	76,4	77,3	76,9	78,5	79,0	75,8	76,7	
Winter Thermal Efficiency ⁽²⁾	%	84,4	84,9	84,7	86,0	86,2	83,9	84,5	
Nominal airflow rate	m ³ /h	410	650	1000	1620	2150	3040	3980	
Electrical power consumption	kW	0,19	0,29	0,49	0,84	1,19	1,27	1,78	
Installed electrical power	kW	0,35	0,35	0,70	1,45	1,50	2,20	4,42	
SFP _{int}	W/(m ³ /s)	950	670	988	1066	1127	861	994	
SFP _{lim} 2018	W/(m ³ /s)	1186	1202	1176	1196	1190	1059	1045	
Front speed at design range	m/s	2,18	1,61	2,03	2,14	1,93	2,21	2,41	
External nominal pressure $\Delta p_{s, ext}$ ⁽³⁾	Pa	150	150	150	150	150	150	150	
Internal pressure drop $\Delta p_{s, int}$ Supp./Ret.	Pa	187/163	117/95	187/157	199/176	190/169	199/174	240/203	
Fans static efficiency (UE) n.327/2011	%	33,2	31,9	33,7	31,5	30,1	43,2	43,2	
Max. external / internal leakage percentage	%	max 3,5 % at -400 Pa max 5,0 % at +250 Pa							
Energy classification filters		ePM1 55% (F7) ePM10 60% (M5)							
Filter pressure switch		present							
Sound power level ⁽⁴⁾	dB(A)	73	74	78	81	82	83	83	
Sound pressure level ⁽⁵⁾	dB(A)	59	60	63	66	67	67	67	
Power supply	V/ph/Hz	230/1/50				400/3/50			

⁽¹⁾ ratio between the thermal gain of the inlet air and the thermal loss of the exhaust air, both referred to the external temperature, measured under dry reference conditions, with balanced mass flow and a thermal difference of the internal/external air of 20K, excluding the thermal gain generated by the fan motors and the internal leakage, in accordance with the provisions of attached V of EU Regulation No 1253/2014

⁽²⁾ outside air: -5 °C / 80% RH - Inside air: 20 °C / 50% RH

⁽³⁾ performance with clean filters

⁽⁴⁾ sound power level calculated in accordance with EN 3744

⁽⁵⁾ sound pressure level measured at 1 m free field distance, in accordance with EN 3744

OPERATING LIMITS

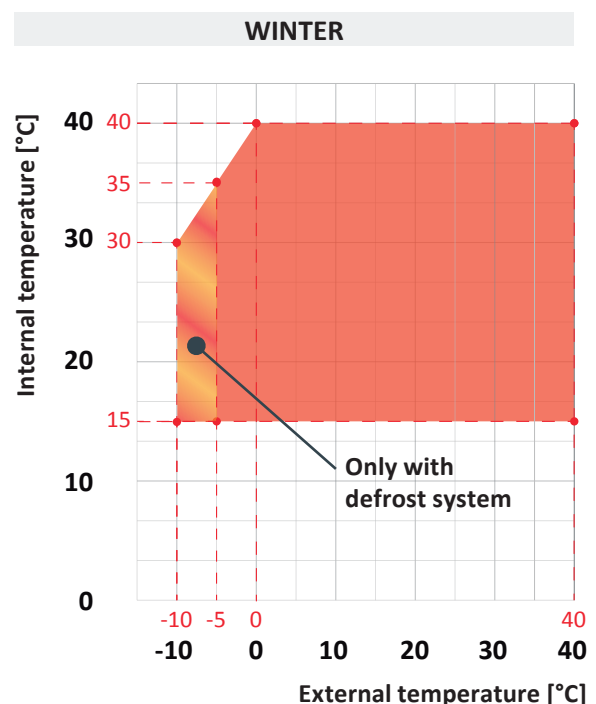
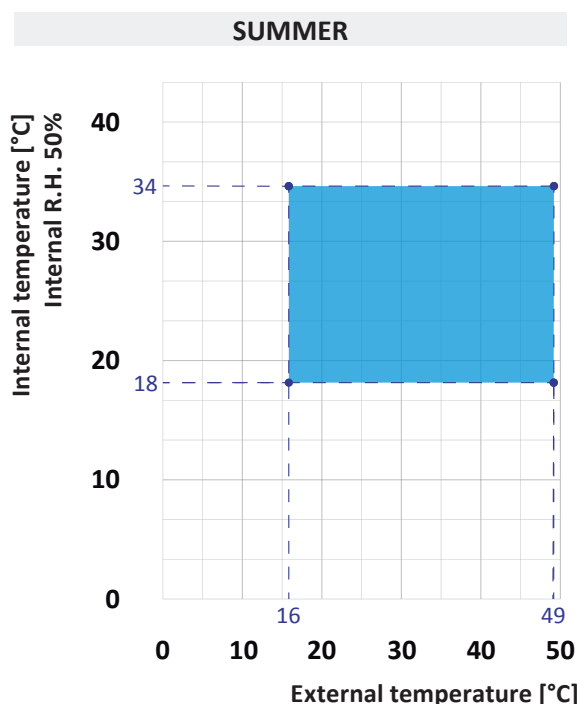

CONTROL

The units are supplied complete with control system and available in the version **ECO**, **PLUS** and **TOP**.

ECO: complete with air temperature sensors installed on the fresh air intake and on room return air. The control allows to select, in stepless mode, the supply and return fan speeds and automatically manages the heat recovery by-pass damper through the motorized On/Off control, summer/winter seasonal change over, and programming for daily time zones.

An optional hot water or cold water coil may also be managed, controlled by a 3-way modulating valve through the room return air sensor. The optional electric post-heating coil is also managed in modulating mode (always via the room return air sensor).

The control alerts the user when filters need replacing (the clogged state of the filters is monitored by a pair of differential pressure switches supplied as standard) or the onset of any alarm; this may also be integrated into modern home automation systems via RS485 serial port with Modbus protocol.

PLUS: this control option is set to operate at constant pressure, it is supplied complete with pressure transducer and air temperature sensors installed on the fresh air intake and room return air.

The control system allows to select, in stepless mode, the supply and return fan speeds and automatically manages the heat recovery by-pass damper through the motorized On/Off control.

It also manages the summer/winter seasonal change over and programming for daily time zones.

The control can also manage an optional hot water or cold water coil through a 3-way modulating valve and an additional supply air sensor in order to maintain a fixed point operating logic.

The same logic can also be used to manage an electric post-heating coil, if present. The control alerts the user when filters need replacing (the clogged state of the filters is monitored by a pair of differential pressure switches supplied as standard) or the onset of any alarm; this may also be integrated into modern home automation systems via RS485 serial port with Modbus protocol.

TOP: this control option is set to operate at constant air-flow, it is supplied complete with pressure transducer and air temperature sensors installed on the fresh air intake and room return air.

The control system allows to select, in stepless mode, the supply and return fan speeds and automatically manages the heat recovery by-pass damper through the motorized On/Off control.

It also manages the summer/winter seasonal change over and programming for daily time zones.

The control can also manage an optional hot water or cold water coil through a 3-way modulating valve and an additional supply air sensor in order to maintain a fixed point operating logic.

The same logic can also be used to manage an electric post-heating coil, if present.

The system alerts to the user when filters need replacing (the clogged state of the filters is monitored by a pair of differential pressure switches supplied as standard) or the onset of any alarm and this may also be integrated into modern home automation systems via RS485 serial port with Modbus protocol.



LCD REMOTE GRAPHIC DISPLAY

All units are supplied complete with a remotable control panel with LCD graphic display.

The clean and modern lines and the installation options, panel or wall mounted (with its own power supply or from a controller), make them easy to integrate into any type of environment.

ACCESSORIES

ISO coarse 40% (G2) grease air pre-filter

The filter is used in the presence of dust and large pollutants suspended in the air or in case of filtration of oily mists. It may be installed as pre-filter in combination with the ePM₁₀ 60% (M5), ePM₁ 55% (F7) or ePM₁ 80% (F9) filters, located on the room air return side.

ePM₁₀ 50% (G4) air pre-filter

The filter media has a low pressure drop and it may be installed as pre-filter in combination with the ePM₁₀ 60% (M5), ePM₁ 55% (F7) or ePM₁ 80% (F9).

ePM₁₀ 60% (M5) air filter

The filter media has an ePM₁₀ 60% (M5) filtering degree, according to ISO 16890 and has a large filtering surface area that guarantees long operating life and less frequent replacements.

eMP₁ 55% (F7) air filter

The filter media has an ePM₁ 55% (F7) filtering degree, according to ISO 16890 and has a large filtering surface area that guarantees long operating life and less frequent replacements.

ePM₁ 80% (F9) air filter

The filter media has an ePM₁ 80% (F9) filtering degree, according to ISO 16890 and has a large filtering surface area that guarantees long operating life and less frequent replacements.

Additional filter rails

The additional filter rails are used when a second filter, in series with the one used as standard, is required.

Electric defrost system

The automatic defrost system (optional) consists of a self-regulating electric coil in PWM input power mode, installed on the return air intake. The system is controlled by a special temperature probe positioned on the exhaust air and guarantees a considerable reduction of the input power compared to traditional systems available on the market.

Unbalanced airflows defrost system

The defrost system (optional) consists of a specific device and software that avoid an excessive drop of the exhaust air temperature slowing down the supply and return airflow and, in case the opening of the by-pass damper.

This system is normally supplied in combination with the hot water coil (optional).

Electric re-heating battery (internal)

All units may be equipped with an internal re-heating electric battery, made up of armoured steel electric heaters, supplied complete with PWM control system, safety thermostat already wired and installed on board.

Hot water coil (external)

The hot water coils are supplied in a dedicated section to be installed in the supply air-flow line. The casing has the same sizes and features of the main unit and it is fixed with a dedicated installation kit supplied with it. The coil is manufactured with copper pipes thickness 0,4 mm and aluminium fins thickness 0,11 mm. The pipes are mechanically expanded in the aluminium fins to increase the thermal exchange rate. On request, it is possible to install coils with different capacities from the standard ones, when previously agreed with the factory.

Cold water coil (external)

The coil is manufactured with copper pipes thickness 0,40 mm and aluminium fins thickness 0,11 mm.

The pipes are mechanically expanded in the aluminium fins to increase the thermal exchange rate. On request, it is possible to install coils with thermal performances different from the standard ones, when previously agreed with the factory. The cooling coil section is supplied complete with condensate drain pan with side water discharge.

3 way modulating valve

It consists of a kit including the 3-way valve for the control of the water flow, to be combined with the hot and/or cold water coil, and its modulating electric actuator.

Connection and fitting devices not included (to be arranged for by the installer).

Air damper with actuator

It operates to exclude the fresh air intake and/or the room return air flow. This option is particularly useful in areas with very cold winter temperatures, where it is necessary to avoid dangerous self-induced cold air flows by the installation itself, during the stand-by period of the unit, with the risk of freezing the water contained in the water coils, if any.

The damper is controlled by On/Off actuators for the opening or the closing, or with return closing spring.

Sound attenuator

The sound attenuator consists of a cylindrical section made in galvanized steel sheet, containing a mineral wool sound proofing material covered with glass wool jacket and perforated galvanized steel sheet containment. The soundproofing material is class M0. The construction avoids any risk of mineral wool fraying even at high air speeds. The cylindrical section is fixed to the unit by screws.

CO₂ probe

ECO version units can be equipped with air quality CO₂ probe. This accessory is installed and wired in the factory. If it's installed on the return air duct it allows to determine the quantity of carbon dioxide present in the environment, increasing the quantity of external air to dilute its content.

ATTENTION: The CO₂ probe is not available in PLUS and TOP versions.

MODEL		005	006	010	015	020	030	040
ECO	EC Brushless supply and return fans	■	■	■	■	■	■	■
	Supply and return differential pressure switches	■	■	■	■	■	■	■
	100% by-pass damper with electric actuator	■	■	■	■	■	■	■
	Microprocessor control	■	■	■	■	■	■	■
	Remotable control panel with LCD graphic display ⁽²⁾	■	■	■	■	■	■	■
	Built-in control sensors	■	■	■	■	■	■	■
	MODBUS RS485 serial interface card	■	■	■	■	■	■	■
PLUS	EC Brushless supply and return fans	■	■	■	■	■	■	■
	Supply and return differential pressure switches	■	■	■	■	■	■	■
	Fans differential pressure transducers	■	■	■	■	■	■	■
	100% by-pass damper with electric actuator	■	■	■	■	■	■	■
	Microprocessor control	■	■	■	■	■	■	■
	Remotable control panel with LCD graphic display ⁽²⁾	■	■	■	■	■	■	■
	Built-in control sensors	■	■	■	■	■	■	■
	MODBUS RS485 serial interface card	■	■	■	■	■	■	■
	Constant PRESSURE version	■	■	■	■	■	■	■
TOP	EC Brushless supply and return fans	■	■	■	■	■	■	■
	Supply and return differential pressure switches	■	■	■	■	■	■	■
	Fans differential pressure transducers	■	■	■	■	■	■	■
	100% by-pass damper with electric actuator	■	■	■	■	■	■	■
	Microprocessor control	■	■	■	■	■	■	■
	Remotable control panel with LCD graphic display ⁽²⁾	■	■	■	■	■	■	■
	Built-in control sensors	■	■	■	■	■	■	■
	MODBUS RS485 serial interface card	■	■	■	■	■	■	■
	Constant AIRFLOW version	■	■	■	■	■	■	■
Accessories	ISO Coarse 40% (G2) grease pre-filter on return air	□	□	□	□	□	□	□
	ePM ₁₀ 50% (G4) pre-filter on supply and return air	□	□	□	□	□	□	□
	ePM ₁₀ 60% (M5) filter on supply and return air	□	□	□	□	□	□	□
	ePM ₁ 55% (F7) filter on supply and return air	□	□	□	□	□	□	□
	ePM ₁ 80% (F9) filter on supply and return air	□	□	□	□	□	□	□
	Additional filter rails	□	□	□	□	□	□	□
	Electric defrost system	□	□	□	□	□	□	□
	Unbalanced airflows desfrost system	□	□	□	□	□	□	□
	Electric post-heating coil	□	□	□	□	□	□	□
	Hot water coil ⁽¹⁾	□	□	□	□	□	□	□
	Cold water coil ⁽¹⁾	□	□	□	□	□	□	□
	Kit 3 way modulating valve ⁽²⁾	□	□	□	□	□	□	□
	Fresh air / Exhaust air damper	□	□	□	□	□	□	□
	On/Off damper actuator	□	□	□	□	□	□	□
	Rounded outlets kit (4 Pcs.)	-	-	-	-	-	□	□
	Sound attenuator ⁽¹⁾	□	□	□	□	□	□	-
CO ₂ probe (available only for ECO version)	□	□	□	□	□	□	□	

■ Standard □ Optional - Not available

⁽¹⁾ Mounted in a separate box

⁽²⁾ Supplied loose

DIMENSIONAL DRAWING - configurations H

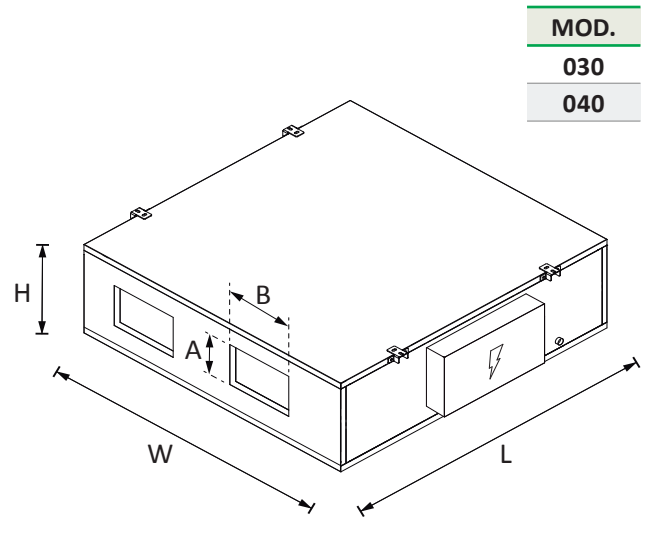
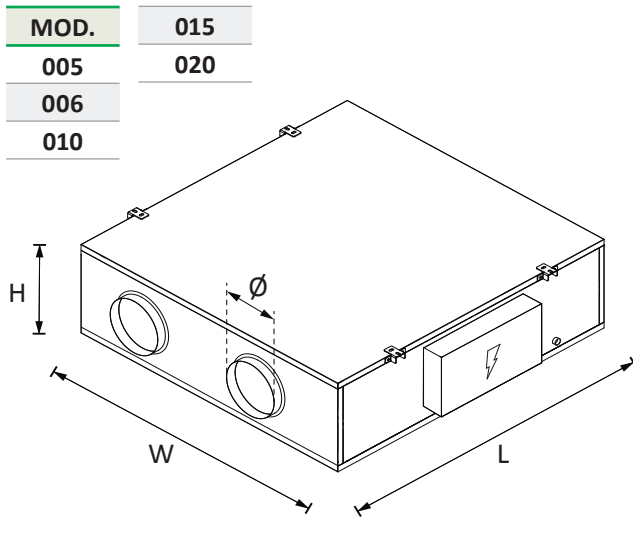

WEIGHTS AND DIMENSIONS

MODEL		005	006	010	015	020	030	040
L	mm	1250	1350	1350	1600	1600	1900	1900
W	mm	700	1000	1300	1300	1550	1650	1900
H	mm	340	380	380	500	500	580	580
Ø / BxA	mm	Ø 150	Ø 200	Ø 250	Ø 250	Ø 250	450x350	450x350
Weight *	kg	89	108	138	172	212	284	354

* Weight is referred to the main unit (without accessories)

CONFIGURATIONS (plan view)

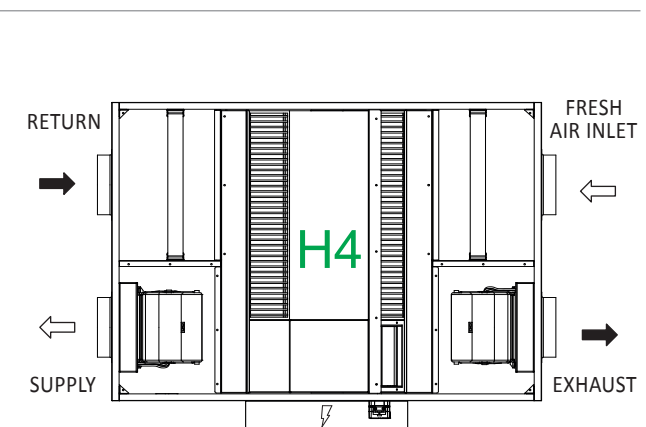

DIMENSIONAL DRAWING - configurations V

MOD.
005
006
010
015
020

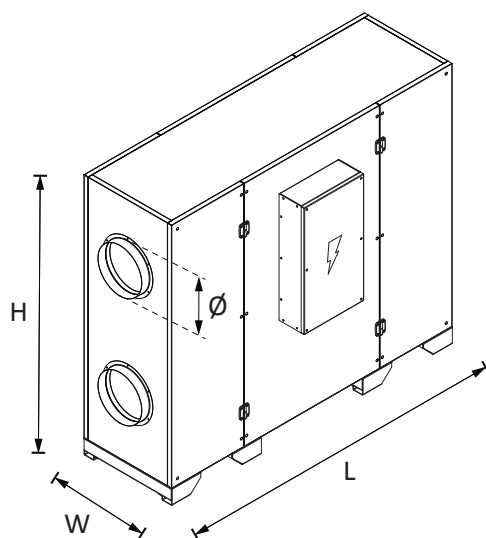

WEIGHTS AND DIMENSIONS

MODEL		005	006	010	015	020	030	040
L	mm	1250	1350	1350	1600	1600	-	-
W	mm	340	380	380	500	500	-	-
H	mm	772	1072	1372	1372	1622	-	-
Ø	mm	Ø 150	Ø 200	Ø 250	Ø 250	Ø 250	-	-
Weight *	kg	92	112	142	178	218	-	-

* Weight is referred to the main unit (without accessories)

CONFIGURATIONS (front view)

